

A STUDY ON USAGE AND OPERATION OF GRAIN MATERIAL HANDLING EQUIPMENTS

Abstract

The range of unit actions, such as loading, transporting, and unloading of items, are all included in material handling. When handling materials is referred to as mechanical handling of materials, many sorts of tackles, gadgets, and equipment are employed to perform it safely and affordably. Since early man learned how to utilise wheels and levers, materials have been moved mechanically. Any human action involving materials requires management of those items. However, the word "materials handling" is used to refer to industrial activities in the fields of engineering and technology. In contrast, contemporary materials-handling systems place a strong emphasis on the seamless flow of items from the source of raw materials to the end consumer. This can be accomplished by moving items in bulk and in standardised units, by employing cranes, conveyor belts, and other devices during handling operations, and by carefully coordinating the movement of goods with manufacturing, processing, and distribution schedules. Recent advancements in bulk transportation aim to reduce handling requirements at all stages, maintain materials in units for as long as feasible, and reduce unit prices.

Keywords: mechanical method; food grains; bulk; storage; equipment

Authors

Minali Masih

Student

Department of Agricultural Processing and Food Engineering

Sam Higginbottom University of Agriculture

Prayagraj, Uttar Pradesh, India

minali1421@gmail.com

Jaya Kumari

Student

Department of Agricultural Processing and Food Engineering

Sam Higginbottom University of Agriculture

Prayagraj, Uttar Pradesh, India

jaya.11mishra@gmail.com

Tushar V Desale

Student

Department of Agricultural Processing and Food Engineering

Sam Higginbottom University of Agriculture

Prayagraj, Uttar Pradesh, India

tush.desale13@gmail.com

I. INTRODUCTION

The grains are transferred, transported, or conveyed from one location to another after harvesting. All of these operations were done manually in former times. Humans handled the threshing and bagging of the grains. Deliveries for mechanical handling are designed to make human labour easier. The milled food products were manually brought to customers after passing through storage and milling facilities multiple times with the grains. As a result, grains were treated excessively, which resulted in higher costs and laborious labour. Modern mechanical machines can now handle higher amounts of grains with a certain amount of human labour, augment it, or even replace it in some cases. The most typical types of mechanical grain handling equipment comprise;

1. Belt conveyor
2. Bucket elevator
3. Screw conveyor
4. Pneumatic conveyor

A variety of material handling systems were needed to handle raw materials, intermediate goods, or finished products from the point of receipt and storage of raw materials through production processes and up to finished goods storage and dispatch points in any industry, including the food industry, whether it was large or small, involving manufacturing or construction type work. The value of the product is not increased by materials handling because it is not a manufacturing process. It should be eradicated, or at the very least minimised, because it also costs money. However, the crucial argument in favour of materials handling is that it boosts output.

1. Belt conveyor

- **Introduction:** The belt conveyor is a flexible, cost-effective, and dependable continuous transportation system with a wide range of uses. This, which is comprised of rubber sat on mesh-threaded mesh, is used to transmit material from one location to another. The belt travels around these two pulleys, which include a head pulley that is connected to the motor and a tail pulley. With the aid of the head pulley's power, the belt spins while the material on it is moved from one location to another. The head and tail pulleys are roughly the same size. The head pulley is attached to the gear box, which is connected to the high-rpm motor. The gearbox lowers the rpm while raising the torque. High torque is necessary for the belt's high load capacity. The head pulley has lagging to improve the grip.

The conveyor's initial cost is largely made up of the belt. The conveyor belt serves as both a carrier and a tensioning mechanism. The belt must withstand all damaging forces that may occur in practise, such as tensile force, stretch, friction, impact, wrapping, bending, wear, chemical (oil and grease) and climatic impacts, and static electricity for many years in order to perform these duties.

- **Operation and main parts:** To improve the belt's arc of contact with the head pulley for greater grip and to prevent belt slide, a snub pulley is fastened next to it. The angle is raised to greater than 180°. Take-up pulleys are necessary because they store a

backup belt in case the primary belt becomes damaged. This pulley may be modified to suit the conveyor's requirements. Maintaining belt tension ensures that the belt rotates correctly in all pulleys, which is one of its additional functions. An empty box of sand may occasionally be hung from the take pulley to provide weight. The belt travels to the take up pulley after the pulley is gently bent using the bend pulley. This kind of conveyor requires two bend pulleys. This belt conveyor is used mostly in industries and was inclined between 15 and 17 degrees. The belt conveyor may move at a speed of 45 to 150 m/min, although normally, 45 to 60 m/min is recommended. The numerous belt conveyors deployed in the industries typically have widths between 1.2 and 1.5 metres.

The structure installed in the frame needs to be supported, hence carrying idlers and return idlers are needed. Idlers for carrying support the conveyor belt when carrying big loads and are free to move since they are connected by bearings. Ten metres separate two carrying idlers from one another. For the smooth operation of the belt conveyor, a horizontal idler is installed between the two inclined carrying idlers. The impact load of the belt is absorbed by the impact idler. They are utilised when a cargo is dropped onto a conveyor belt from a height where it won't damage the belt or the other components.

Classification of belt conveyor

1. According to shape

- Flat belt conveyor
- Trough belt conveyor

2. According to geometry

- Horizontal
- Inclined
- Combined
- Inclined horizontal
- With two or more bends

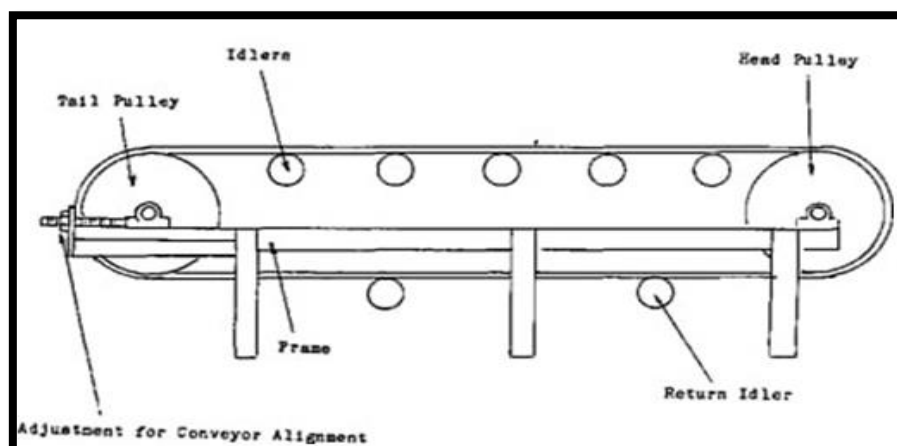

(Source: Internet)

Figure 1: Belt Conveyor

2. Bucket elevator

- **Introduction:** A particularly effective tool for the vertical transportation of bulk grains and derivatives is the bucket elevator. While the bucket elevator's fundamental architecture has remained mostly unaltered over the years, its possibilities have expanded thanks to expertise and the use of new building techniques. A bucket elevator is a piece of driven machinery that uses an unending chain to transport bulk goods along a vertical or steeply inclined course.

Due to its 90-degree angle with the surface, this type of conveyor may be employed in compact spaces. Long inclined belt conveyor is presently being replaced by it. It features two major sprockets: a driving sprocket at the top and a driven sprocket at the bottom. Both sprockets are connected to one another by a thick chain, which is furnished with several metallic buckets. These buckets raise the materials as the driving sprocket turns. The buckets travel in a single direction inside a casing, collecting bulk materials at the equipment's bottom end and delivering them at the top. The vertical lift might be anything from a few metres to over 50 metres. From 2 to 4 t/hour to 100 t/hour, the capacity ranges.

The link between the conveying speed, bucket contents, bucket design and spacing, bucket loading and unloading methods, and bulk product characteristics is what determines a bucket elevator's conveying capacity. At reasonably high belt speeds, bucket elevators with a belt carrier can be employed.

- **Operation and main parts:** Bucket elevators use a large number of buckets that are installed at regular intervals as an unending string on a belt to transfer the granular bulk products upward in a continuous pulsating product flow. At the top and lower ends, a pulley is crossed by the bucket-conveyor belt. The bottom pulley is designed as a return and tension pulley, and the head pulley is driven. The belt may be used to pull and carry things. The belt's ascending and descending sections often run in tandem or independently in a trunk. The elevator head portion is carried by this trunking, which is attached to the elevator boot section. One or two input chutes are present on the elevator boot. The discharge chute at the elevator head's end collects the product flow for further transfer. Gravity or centrifugal force are used to discharge the product flow. Given the elevator's carrying capacity, the manner of picking up below and dropping down upstairs is of vital importance. Important variables include the contents and form of the buckets, the bucket spacing, the speed of the belt, the diameter of the pulleys, and others.

Types of bucket elevator according to mode of discharge of materials

- Continuous bucket conveyor
- Centrifugal bucket conveyor
- Positive discharge conveyor

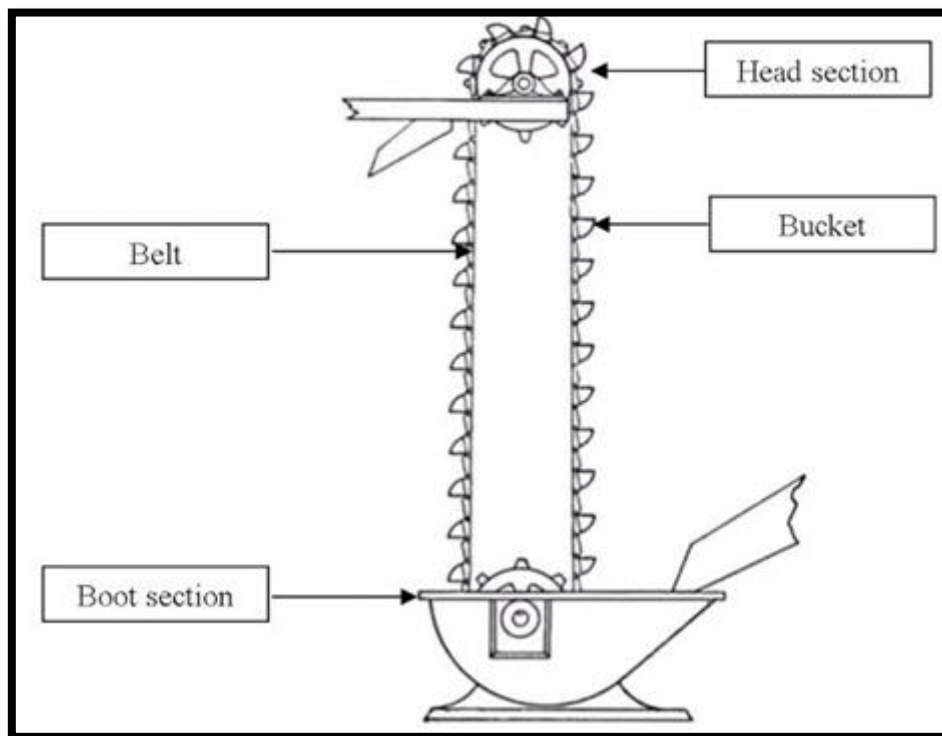

(Source: Internet)

Figure 2: Bucket Elevator

3. Screw conveyor

- Introduction:** Greek scientist Archimedes (287–121 B.C.) created the screw conveyor, the first form of conveyor that is still in use today, in order to raise water. The screw conveyor was used to carry fine bulk goods much later, during the industrial revolution. It was thought that the screw conveyor could only be used sparingly and with very low hourly capacity for the transportation of bulk material. But current practise shows that the number of goods that may be transported by a screw and the transport capabilities are both very great. The screw conveyor is used in breweries, the chemical industry, various food-producing enterprises, animal feed companies, cow fodder firms, and grain processing facilities. Its use as a barge and seagoing vessel unloading gear has been studied during the past few years. The screw conveyor is only effective over short distances when compared to the belt conveyor and the chain conveyor. Compared to most other types of conveyors, it needs greater motor power and is more prone to wear. But compared to other conveyors of the same length and capacity, the screw conveyor's startup expenses are lower. This is because there is no need for a tensioning device and the driving mechanism is simpler.
- Operation and main parts:** The screw conveyor consists of a U-shaped or tubular trough around which a shaft spins while a ribbon is built in the shape of a screw. The product does not need to spin; the ribbon simply propels the product that has entered the trough forward on the bottom of the trough. By using intermediate bearings, the shaft with the welded hélicodal screw blade or helices is supported over predetermined distances. A drive group positioned on one end of the shaft is used to

apply the driving. Screw blade, screw shaft, coupler, trough, cover, input and outlet gates, bearings, and driving mechanism are the key components of the screw conveyor. The screw conveyor is appropriate for the horizontal, inclined, or vertical conveyance of various granular bulk goods depending on the design of the helicoidal screw blade or helix and the RPM. Specific weight, external friction of the product on the trough sidewalls and the screw blade, size and form of the particles, and flow characteristics of the bulk cargo to be conveyed all have a significant impact on the functioning and capacity of the screw conveyor. Both regular and irregular product compositions are possible.

A regular composition is made up primarily of uniformly sized and shaped grains, with just a little quantity of dust. Large lumps and a significant amount of dust make up an uneven composition. Products that flow easily have less friction and can be transported at a reasonable volume. Only when special precautions are taken regarding, for example, RPM, clearance between the screw blade edge and the trough side, and angle of inclination of the screw blade, can products that are adhesive, heavily drying, lumpy, and fibrous, as well as fragile or easily breaking, be transported by means of a screw. In general, lump-heavy items' conveying capacity is lower than that of products with an uniform granular structure. When placed vertically, a screw made for horizontal transportation has a substantially lower hourly capacity. Prior to a few years ago, it was challenging to achieve large conveying capacities with the vertical screw conveyor because the product was propelled away before it reached the tubular trough due to the centrifugal force produced by the screw's movement. It was only possible to carry the meagre amount of the product that was left around the screw. By adding a counter-rotating feeding mechanism to the screw's intake, a vertical screw conveyor's capacity may be significantly improved. Due to the low RPM, the product flow in the screw conveys at a slow rate. The screw width, screw blade inclination, screw blade speed, individual product weight and kind, and loading level all affect the conveyance capacity.

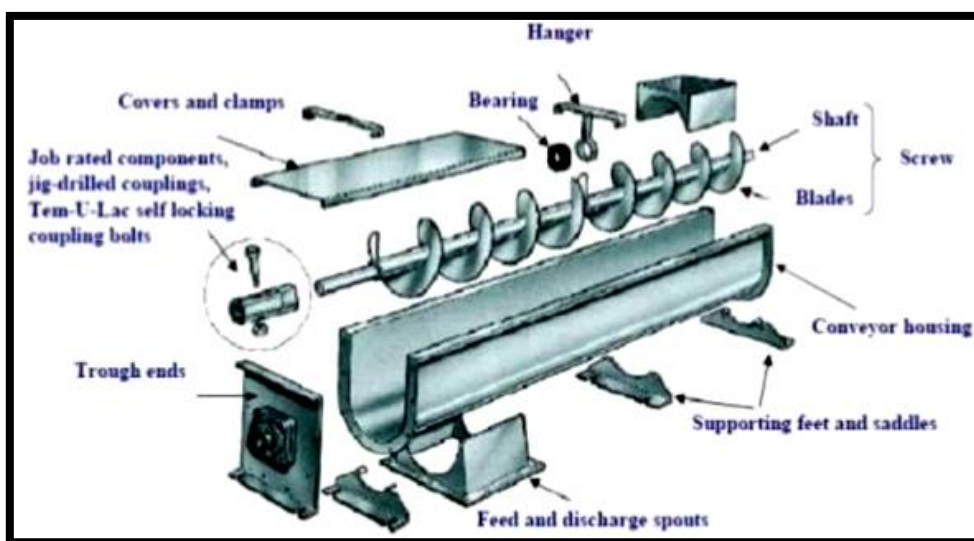

(Source: Internet)

Figure 3: Screw Conveyor

4. Pneumatic conveyor

- **Introduction:** Pneumatic conveyor is mostly used in food processing industry. Pneumatic conveying system is mostly used with bag filter and works with air pressure system. It works with the concept of terminal velocity. As the material falls down with the self-weight and gravitational force, the opposite resistant force moving upwards is exerted which is called drag force. The granular materials are conveyed through pneumatic conveyor in food processing industry.

The basic components of conveying system are blowing system, feeder, conveying pipe/duct, bag filter. Bag filter is used to stop the granular materials going out of the silo.

By employing air at a pressure higher than atmospheric, the blowing or positive pressure system moves the product. The blowing system, which is perhaps the simplest and most fundamental of all systems. A fan or blower, an air-lock feeder for delivering the product into the system, tubing or pipes, and an appropriate air/product separator are the main components of a blower system. The product enters the system from the bottom of a hopper and is transported down the pipeline to the discharge point or receiver while being carried in suspension with the air. The rotating air lock's RPM may be simply adjusted to manage the feeding rate. A combined cyclone-bag filter configuration can be employed for goods with a wide particle size dispersion. Long-distance transportation and the distribution of granulated goods from a storage silo to various consumption sites involve the usage of pressure type conveyors. By employing air at a pressure that is lower than atmospheric or negative, the suction or vacuum system moves the product.

The exhauster is located at the discharge end, which distinguishes this system from the positive pressure system. A product/air intake nozzle and an appropriate product separation mechanism, which is nearly identical to that of the suction system, are the essential components of vacuum systems. When the product needs to be moved from a number of feed stations to a single central delivery point, vacuum type conveyors are typically employed. The size of pipe that can be utilised has no technical restrictions. Larger pipes, exhausters, and thus larger support structures are needed for increased capacity.

- **Operation and main parts:** Bag filter is fitted with two systems, the first one is master dome and the other following is slave dome. At the top of the dome a dome valve is attached which is connected with pneumatic cylinder, this valve separates hopper and dome chambers. The pneumatic cylinder is controlled electronically, and it operates according to the signal. When cylinder is closed the dome valve opens and at that time the material from the hopper comes to the dome this process is called loading time. After that the cylinder is opened and the dome valve is closed. The air pressure 5-7 bar takes along the material to the next place. This process is called conveying time. This process continues in a manner of cycle and the timing between loading time and conveying time is called auto delay time. This is being set in seconds electronically. The air pressure line is fitted with non-returning valve such that the material does not go back into the air line. Sometimes suction is also used at that time

the vacuum system is fitted at the discharge end but in the pressure system it is fitted at the feed inlet side.

Types of pneumatic conveying system

- Pressure or blowing system
- Suction or vacuum system
- Combined push pull system

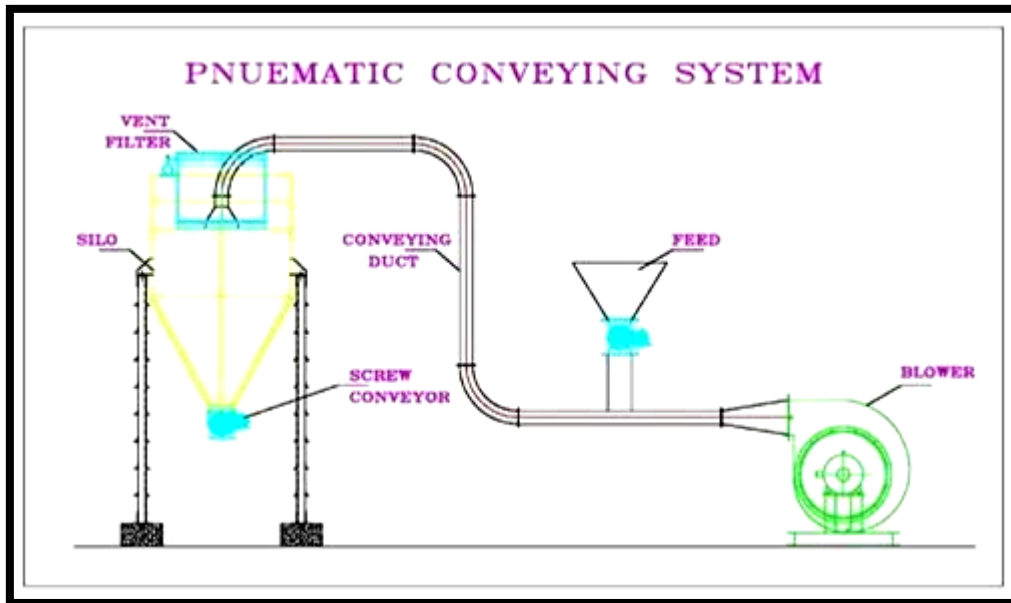

(Source: Internet)

Figure 4: Pneumatic Conveyor

REFERENCES

- [1] IS: 8598:1987, Idlers and Idler Sets for Belt Conveyors, BIS.
- [2] IS:5563-1985, Specification for Screw Conveyors for Industrial Use, BIS.
- [3] IS:12960:1990 (Reaffirmed- 2000) , Determination of Power Requirement of Screw Feeder—
- [4] Spivakovsky, A. and Dyachkov, V., "Conveyors and Related Equipment", Peace Publishers,
- [5] "Belt Conveyors for Bulk Materials," Conveyor Equipment Manufacturers Association, USA.